

PMX

Horizontal hybrid intermittent and continuous motion cartoner

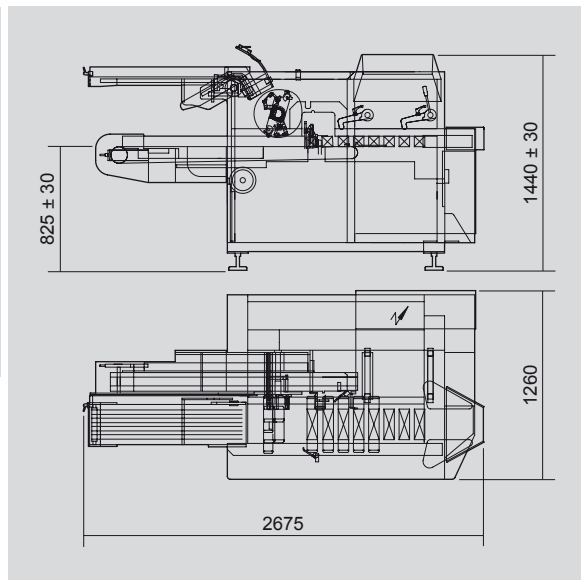
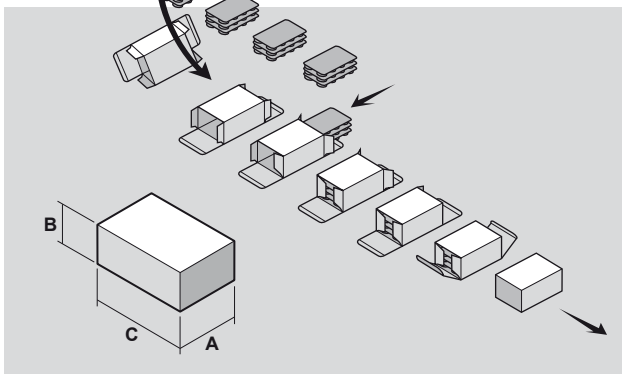

TECHNICAL DATA		PMX 1	PMX 2
Mechanical speed	STROKES/1'	25÷150	25÷110
Motors	KW	1,12	1,12
Power absorption	KW	2,05 (Hot-melt + 3,9)	2,05 (Hot-melt + 3,9)
Air consumption	NI/1'	16,9	16,9
Air pressure	bar	5÷6	5÷6
Gross weight	kg	~1400	~1400
Net weight	kg	~1200	~1200

Size range	PMX 1 min.	PMX 1 max.	PMX 2 min.	PMX 2 max.
A	15	80	20	125
B	12	75	15	75
C	65	200	65	200
A + B	-	170	-	170

