

HV

High speed continuous motion horizontal cartoner

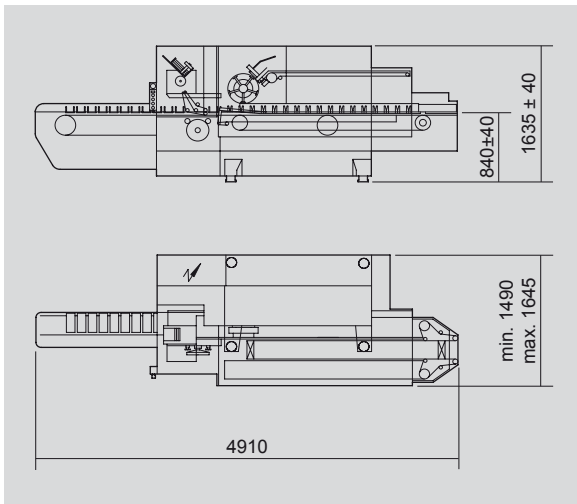
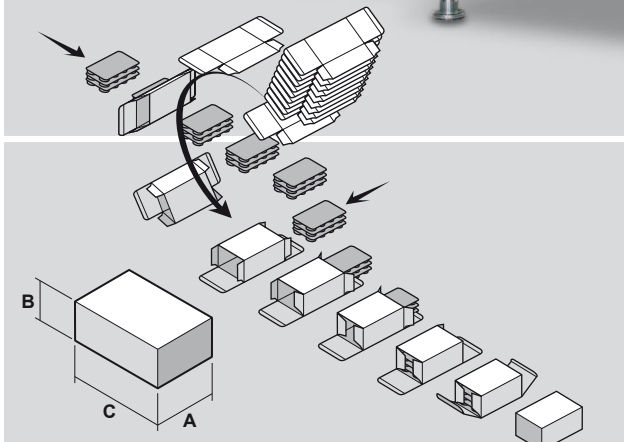
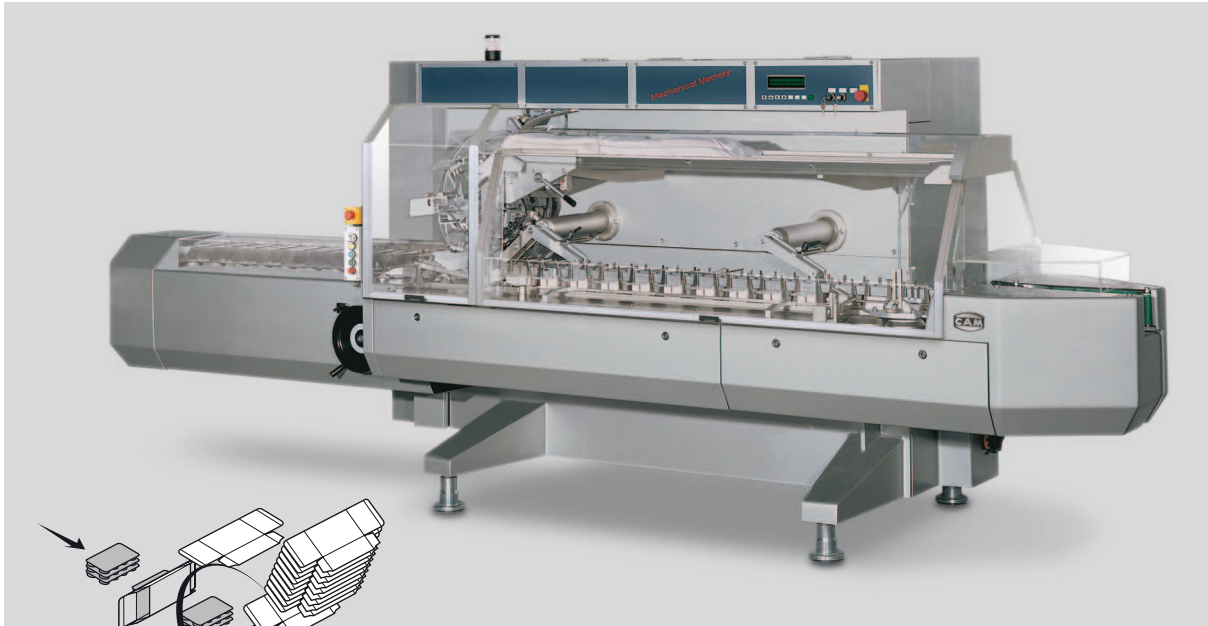

TECHNICAL DATA		HV 1	HV 2
Mechanical speed	STROKES/1'	max. 400	max. 260
Motors	KW	4,25	4,25
Power absorption	KW	5,20 (Hot-melt + 3,9)	5,20 (Hot-melt + 3,9)
Air consumption	NI/1'	16,9	16,9
Air pressure	bar	5+6	5+6
Gross weight	kg	~3000	~3000
Net weight	kg	~2500	~2500

Size range	HV 1	min.	max.	HV 2	min.	max.
A		20	95		20	160
B		12	70		12	70
C		70	230		70	230
A + B		-	165		-	200

