

# L112/L212

## High speed continuous motion liquid filling and capping monobloc

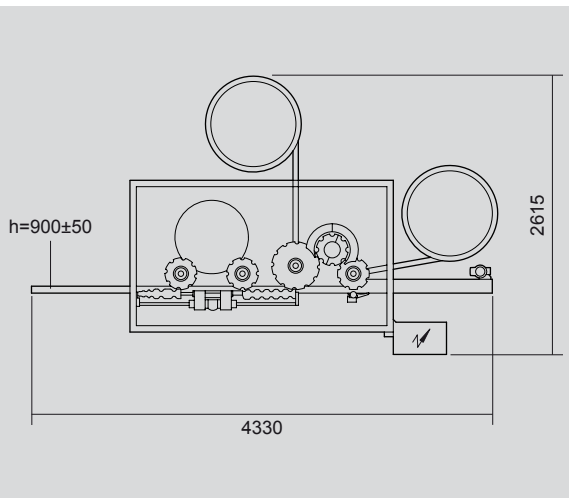

TECHNICAL DATA		L112	L212
Mechanical speed	<b>STROKES/1'</b>	80+400	80+400
Power absorption	<b>KW</b>	5	7
Air consumption	<b>NI/1'</b>	100	100
Air pressure	<b>bar</b>	5+6	5+6
Gross weight	<b>kg</b>	~2000	~2650
Net weight	<b>kg</b>	~1400	~1950
<hr/>			
Size range	<b>min.</b>	<b>max.</b>	
<b>A</b>	15	80	
<b>B</b>	15	80	
<b>Ø</b>	15	80	
<b>C</b>	35	180	

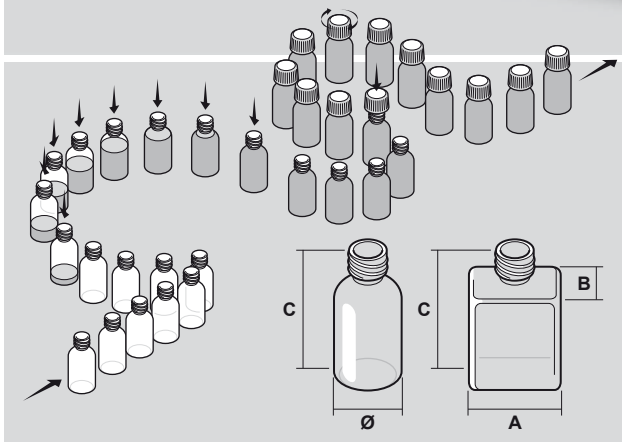
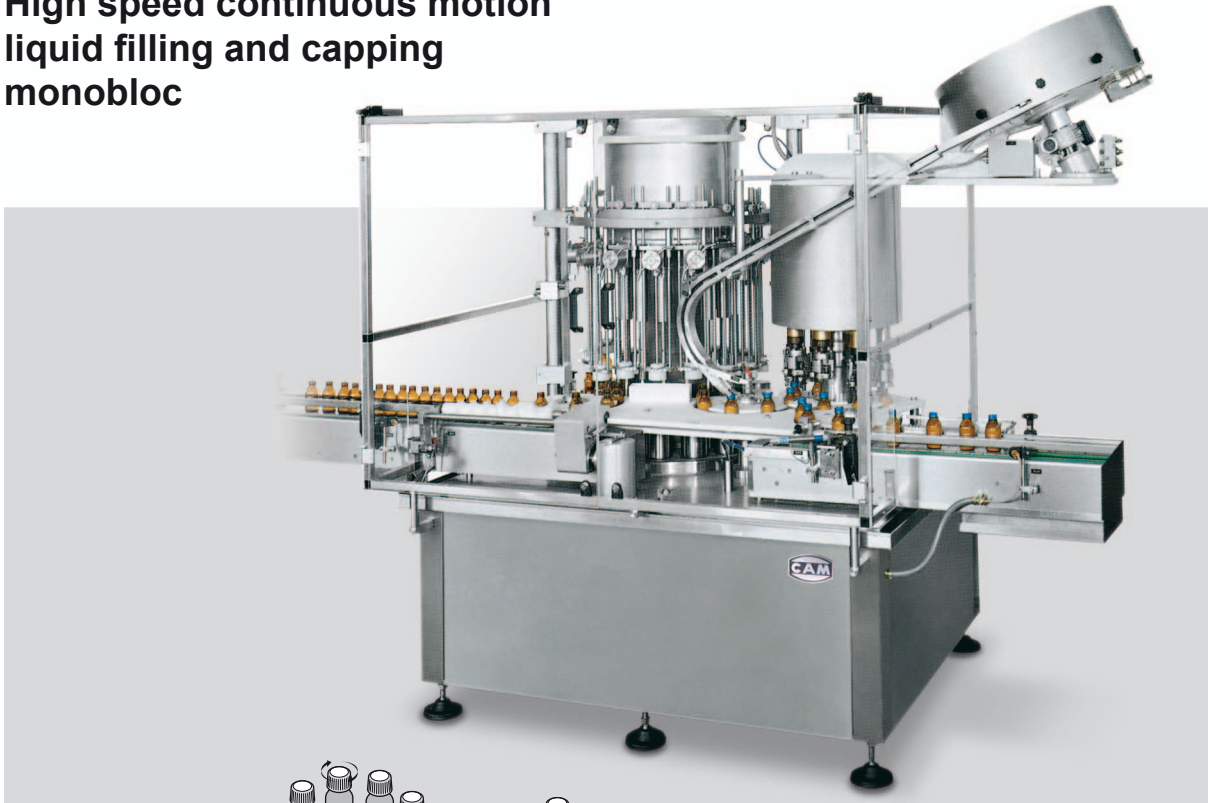