

MC

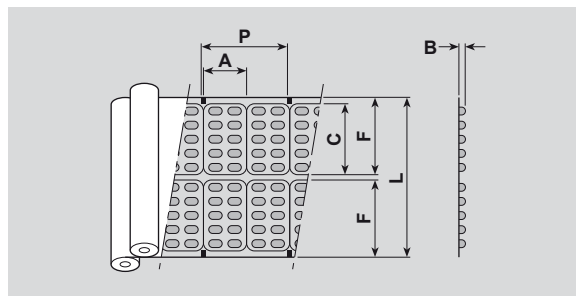

Automatic blister packaging machine with plate sealing

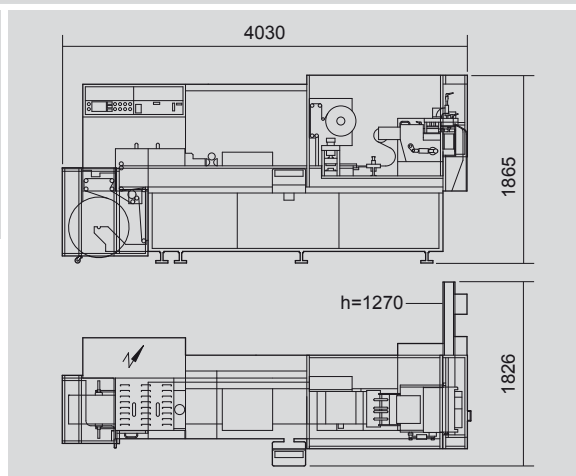
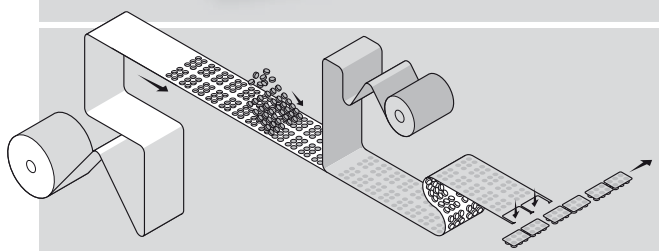
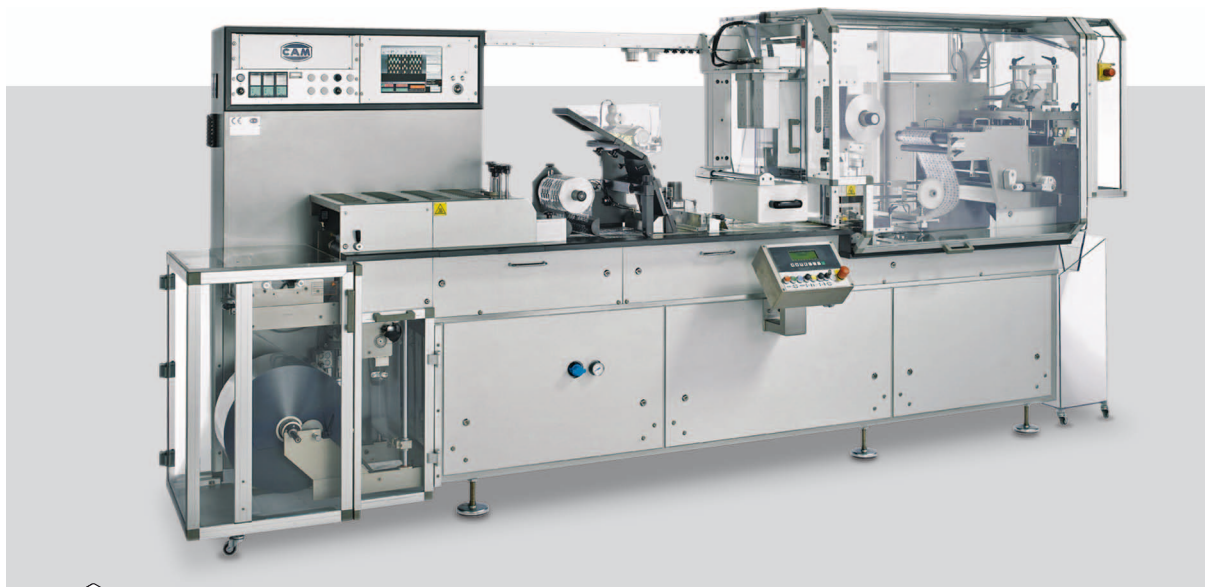

TECHNICAL DATA

Production up to	BLISTERS/1'	300
Mechanical speed	STROKES/1'	20+60
Power absorption (max.)	KW	10
Air consumption	NI/1'	300
Air pressure	bar	6
Gross weight	kg	~2500
Net weight	kg	~1900

Size range	min.	max.
L Web width (mm)	90	286
P Stroke length (mm)	40	90
A Blister width (mm)	30	85
B Forming depth (mm)	3	12
C Blister length (mm)	60	-
F Blister rows across the web	1	3
Blister rows along the pitch (N)	1	2
Number of blisters per cycle (G)	1	6

Forming materials PVC; PVC+PVDC; TRIPLEX; COC; ACLAR; ALU