

# ASB38

Automatic bundler with  
 stretch-banding or  
 shrink-wrapping

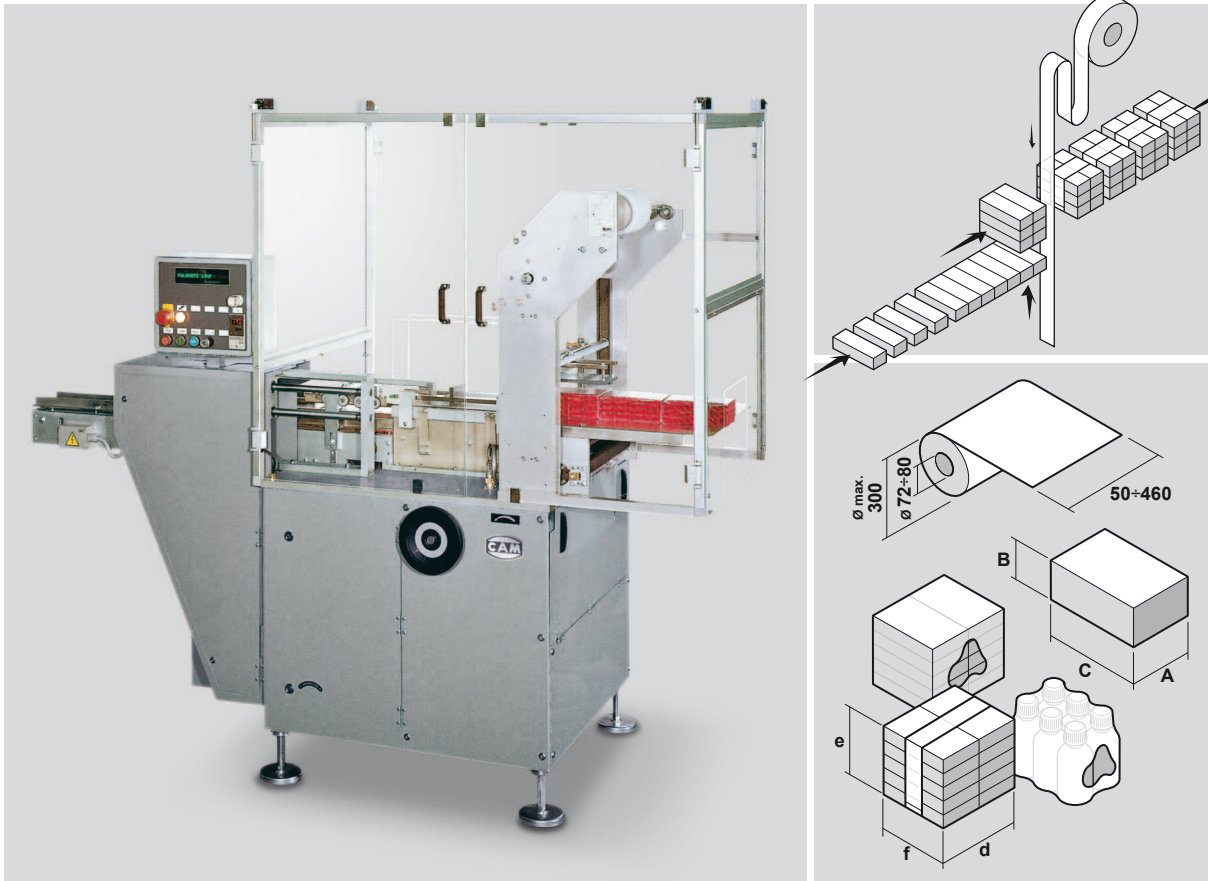

## TECHNICAL DATA

Mechanical speed	STROKES/1'	max. 30
Motors	KW	0,8
Power absorption (max.)	KW	1,7
Air consumption	NI/1'	180+300
Air pressure	bar	5+6
Gross weight	kg	~800
Net weight	kg	~600

Size range	min.	max.
A	15	360
B	12	70
C	50	250
d	40	360
e	24	210
f	50	250

