

MS

Linear continuous motion bottle cleaning machine with blowing and suction system

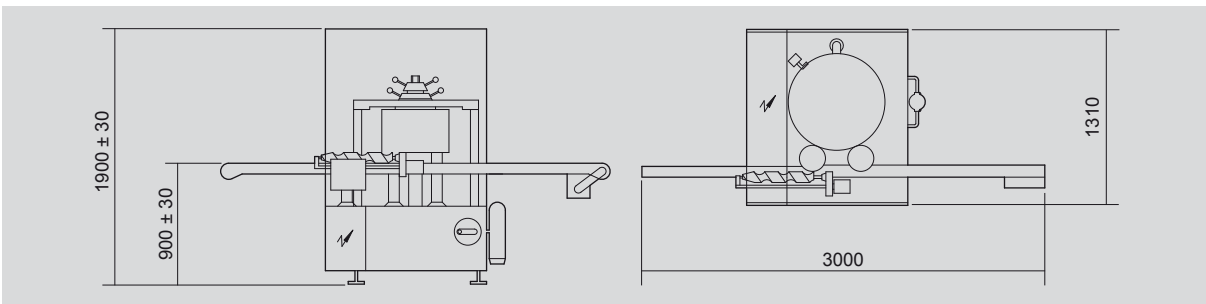

TECHNICAL DATA		MS 8	MS 16
Mechanical speed	STROKES/1'	150	300
Motors	KW	2,2	2,2
Power absorption	KW	3	3
Air consumption	NI/1'	350	600
Air pressure	bar	5+6	5+6
Gross weight	kg	~1900	~1900
Net weight	kg	~1300	~1300

Size range	MS 8 min.	MS 8 max.	MS 16 min.	MS 16 max.
A	20	70	20	50
B	20	70	20	55
Ø	30	85	20	65
C	70	190	50	160

